



1st Virtual Conference on Structural Integrity - VCSII

## IoT sensors for modern structural health monitoring. A new frontier.

Donato Abruzzese, Andrea Micheletti\*, Alessandro Tiero,  
Manuel Cosentino, Damiano Forconi, Gianmarco Grizzi,  
Gianluca Scarano, Sreymom Vuth, Pierluigi Abiuso

*Department of Civil & Computer Science Engineering, University of Rome "Tor Vergata", via del Politecnico, 1 - Roma 00133, Italy*

---

### Abstract

The problem of determining the structural safety level of buildings and civil engineering infrastructures (CEIs) is raising growing concern worldwide. Most of the reinforced concrete constructions have a design life not greater than 100 years, and today it is necessary to face the problem of assessing their level of safety and structural integrity. Such problem is even more pressing when a construction is subjected to extreme environmental conditions. The long-term goal of this study is the realization of wireless low-cost devices, and a data management software, for the structural health monitoring of buildings and CEIs, with remotely controlled sensors embedded in, or installed on, the structural elements, to measure stresses together with accelerations. Once equipped with such system, each construction can become part of the Internet of Things, permitting users and authorities to be alerted in case structural safety is diminished or compromised. A crucial aspect is the unaltered preservation of measurement data over time, which cannot just rely on third parties, and for which it is necessary the exploitation of suitable data-protection technologies. This study have been carried out by experimental testing and validation, both in lab and on site, of the monitoring devices designed and realized. Results show that it is possible to realize low-cost monitoring systems, and related installation techniques, for integration in every new or existing buildings and CEIs

© 2020 The Authors. Published by Elsevier B.V.

This is an open access article under the CC BY-NC-ND license (<http://creativecommons.org/licenses/by-nc-nd/4.0/>)

Peer-review under responsibility of the VCSII organizers

*Keywords:* Permanent structural health monitoring; IoT; structure maintenance; Arduino-based devices, data protection.

---

\* Corresponding author. Tel.: +39-06-72597049.

E-mail address: [micheletti@ing.uniroma2.it](mailto:micheletti@ing.uniroma2.it)

## 1. State of the Art

The importance of efficient Internet of Things (IoT) platforms for structural health monitoring of buildings and civil engineering infrastructures (CEIs) is nowadays widely recognized [1-5], and great effort is currently spent on their development, and testing. It is now obvious that it is necessary to equip structures with permanent monitoring devices, placed at a large number of selected locations, in order to extend their service life and reduce maintenance costs. However, important problems still need adequate solutions: (1) measuring the stress state inside structural elements (columns, beams, connections) simultaneously with the recording of the accelerations at the same location (thus avoiding complications given by the inverse problem), so as to obtain a reliable map of the current safety level of those structural elements and of the structure as a whole; (2) realizing low-cost devices and devising simple sensor installation techniques, permitting the monitoring task to be carried out for both strategic CEIs, and less important buildings and bridges; (3) storing and maintaining the measurement data associated to a certain structure unaltered and uncorrupted during service life, without relying on third parties.

Recently, some researchers achieved significant results regarding both (1) and (2) (see [6-9]), including the realization of a low-cost, small sized wireless strain sensor, whose performances are comparable to those obtained with a professional equipment. It has been estimated that the cost of a monitoring system adopting this device would be only about one percent of the total construction cost [9].

Hung-Fu & Tzu-Kang, on 2018 [10], experienced the possibility to monitor structures in a very effective and easy way, showing better detailed results compared to the traditional systems, thanks to the miniaturization of the sensors and their low cost (Fig. 1).

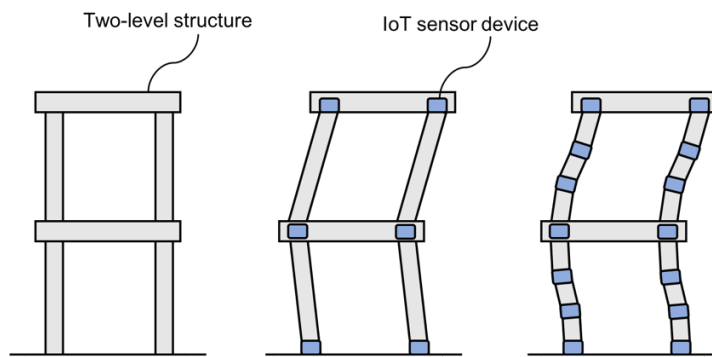

Fig. 1. Deformation obtained by different sensors on the structure (redrawn from Hung-Fu & Tzu-Kang, 2018) [10].

## 2. To foresee the future of structural monitoring

By mean of the new coming technologies, such as IoT, and by applying it to the world of structures, it is easy to imagine how the monitoring activity could be made more efficient. Wide range of applications, e.g., frames (concrete as well as steel) or plates (for instance flat slab, shear wall, large vaulted roof), could be considered for long term or even permanent monitoring, no matter which material is used for the structure, including masonry.

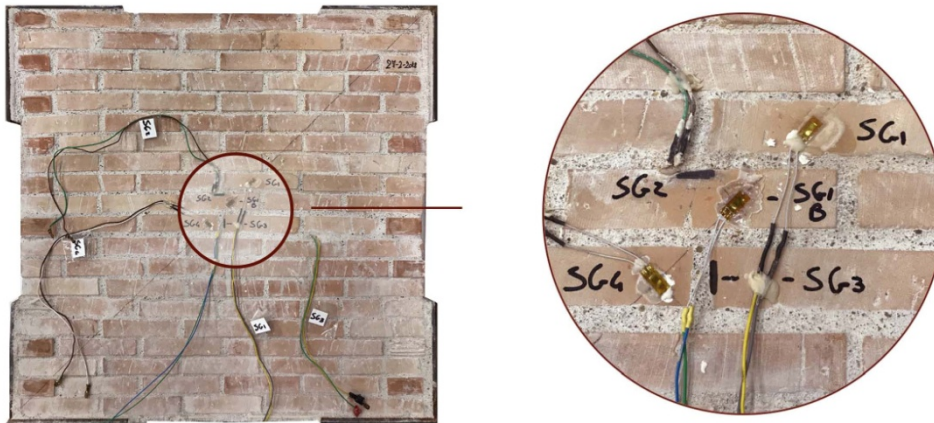

Fig. 2. Sensors installed on a masonry panel.

The diffusion of sensors (strain-gauges, accelerometers, deformometers, or others), all over the structure, will give a sense of neural control of the structure, making real the dream of the structural engineer of controlling any point of the structure, in the continuity of the reality, more than in the discontinuity of the idealized model. Such a detailed control on the structure could include also a real time comparison between the results of the measurements and the results of a simulated numerical model of the structure, possibly also providing some feedback, moving from the condition of a simple control to a more sophisticated “smart control”.

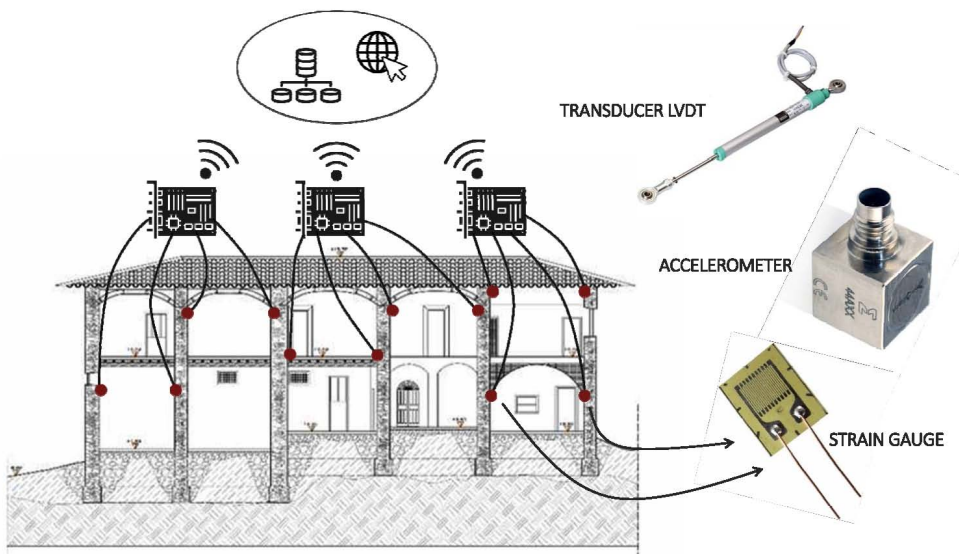

Fig.3. Scenario of future permanent monitoring system in a building.

As shown in Table 1 [11], several are the possible applications inside the IoT technology, and not only related to the comfort or the use of gadgets, but also including safety and structure maintenance, adopting different sensors and control systems.

Table 1 – Smart Environmental application of IoT (reproduced from Chandanshive & Kazi, 2017) [11].

IoT Parameters	Smart Home	Smart City	Smart Water	Smart Transportation
Size of Network	Undersized	Intermediate	Huge	Huge
No. of Users	Limited, restricted to family members	Several, General Public	Not many, mostly access to Government	Big, mostly by common civic
Energy make up	Revivable Battery	Reviveble Battery, Energy Harvesting	Energy Harvesting	Reviveble Battery, Energy Harvesting
Source of Internet	Wi-Fi, 3G, 4G, LTE	Wi-Fi, 3G, 4G, LTE	Wi-Fi, Satellite	Wi-Fi, Satellite
Data management	Confined Device	Mutual Device	Mutual Device	Mutual Device
Gadget	RFID, WSN	RFID, WSN	Single Sensors	Single Sensors, RFID, WSN
Bit-rate requirements	Undersized	Undersized	Undersized	Undersized / Huge

For instance, in 2016, Myers et al. [12] showed the highly advanced technology of the damage detection on a plate with a cut, thanks to the available approach with several piezoelectric sensors and the related network and smart system for elaborating the measurements (Fig. 4).

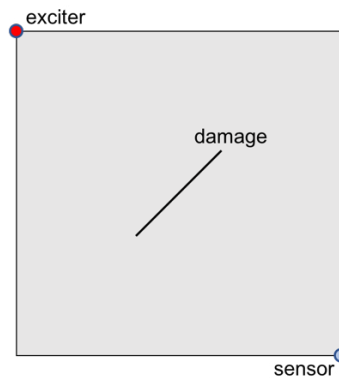

Fig. 4. The damage detection problem for a plate with a cut analyzed in Myers et al., 2016 [12].

If now we want to imagine a perfect monitoring system in civil engineering, at the same level of other field of applied technologies (cars, homes), we can sketch a system with large number miniaturized devices/sensors, low cost and low power consumption, all of them connected in a local network which is definitely wireless, probably based on the most advanced WiFi available on the market (Fig. 5). The use of the WiFi allows for a more convenient position for the sensors, freeing the structure from the physical wiring network, which is still now very common for this kind of situations.

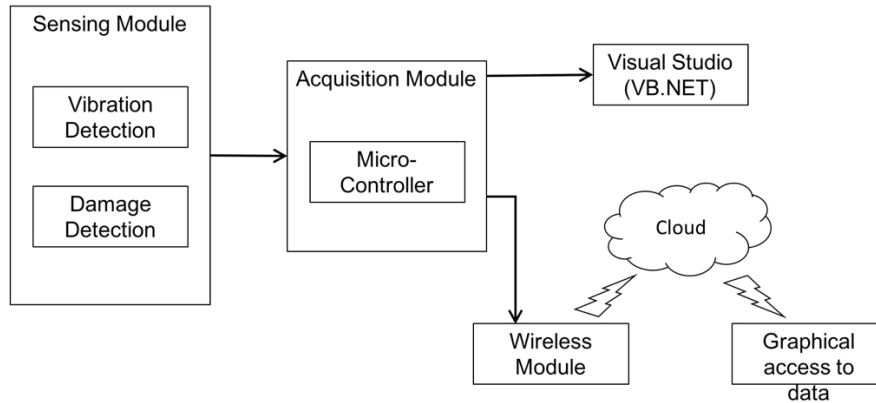

Fig. 5 – The advanced step on the SHM, the wireless platform (redrawn from Chanv et. al., 2017 [13]).

Easy assembling, C++-like programming language, low cost and portability encourage much the researchers to investigate multiple and new applications, sometime with limited knowledge about computer science and electronics. In fact until today many electronic devices have been designed only by the electronics specialist, without much involvement by the civil engineers, while this new “object approach” allow the structure engineers at least to collaborate with the computer sciences and electronics specialists. Of course some limitations remains, e.g. related to if the “MEMS” sensor family have comparable performances or not with the traditional, bigger, heavier, much more expensive sensors. But this has also been the doubt of many of the fans of HiFi (High Fidelity) sound systems, when they were reluctant to leave the 78 rpm records for the Compact Discs, or the valve amplifier for the new transistor devices.

### 3. The reliability of the new compact sensors – MEMS

The daily use of our electronics gadgets and cell phones gave us, unconsciously, the confidence that accelerometer, touch screen, proximity, temperature and other miniaturized sensors, are becoming more and more sensitive and reliable. In our laboratory, before starting the experimental campaign with big and complex structures, we compare the efficiency of one of this devices, in-house designed and built, with a traditional and definitely so-called “reliable” device. The “traditional” device is one multipurpose instrument (Fig. 6), usually used in the laboratory for measuring the stress in some point of the structures by the resistance (in Ohm) of small strain gauges. The difference in cost, considering even some “manual” and “mental” investment by our researcher team, is more than 1:20. When we started this comparison we were almost sure to put inside the ring two different boxers, but we came out with some really surprisingly results, as it can be seen in Fig. 7. On a simple supported steel rectangular bar two strain gauges have been installed in parallel, one connected with the expensive instrument and the other to the “assembled” low cost instrument (Fig. 8). In Fig. 7, SG is the “best” instrument, SG1 is the “cheap” one. No effective difference can be appreciated between the two measurements.



Fig. 6. On the left a traditional multipurpose instrument for lab measurement of strain gauges, on the right the device designed and assembled by the authors.

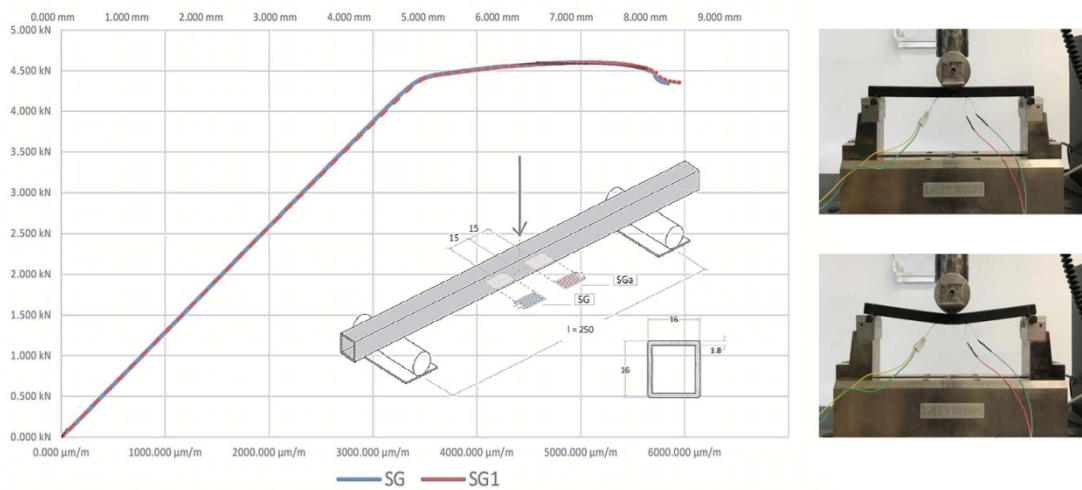

Fig. 7. The result of the traditional vs. low cost/Arduino like instrument. The 2 curves SG and SG1 are almost running on the same path, without any sensible difference valid for practical use.

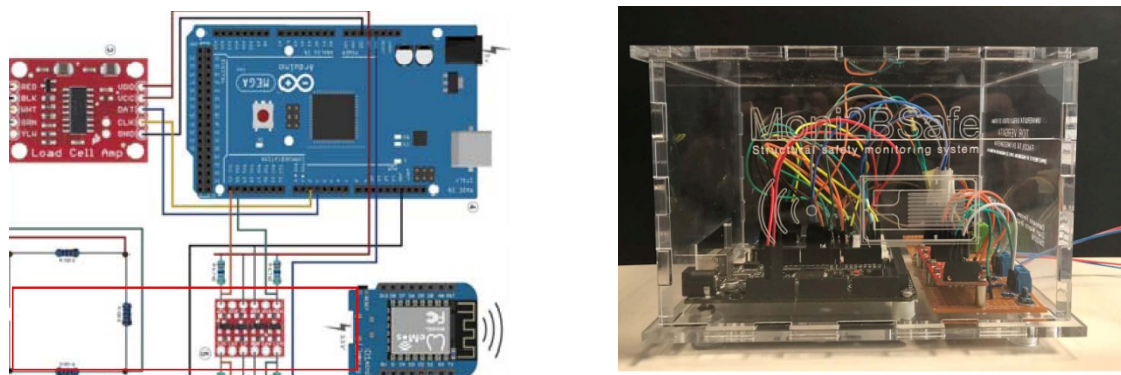

Fig.8. On the left, the typical appearance of the Arduino's-like devices, similar to the one, on the right, assembled in a box, used in the present test.



Fig. 9. The dream of the structural engineer: to have control on structures similarly to what is possible in cars (left image from <https://medium.com>, accessed on Apr 14, 2020, right image from <https://www.patentati.it>, accessed on Apr 14, 2020).

#### 4. Conclusions

Some problems still need to be solved, in case we want to use these compact, low-power consumption, low-cost devices, in the streamline of the IoT. We have to guarantee a robust communication between the peripheral sensors and the central device responsible of collecting data (database) and of processing further results. Considering feasible the use of battery to power the system, also this aspect should be considered for better reliability, to avoid service interruptions. It means that the communication and data management hardware and software system should be reliable in the long term, considering the likely request of a permanent monitoring.

We envisage that within 20 years every new building and civil engineering infrastructure will be built by law with a multitude of embedded sensors which are able to provide information on their current state with regard to structural and other functions, in order to maximize its service life against extreme environmental actions, and to minimize its energy consumption and carbon footprint. The data provided by the monitoring system will be stored permanently and will not be corruptible. Under this point of view, also the protection of the sensible data should be considered, adopting suitable preservation and protection systems. It is inevitable the use of these new technologies, but we should be aware of the limited time experience we have and behave consequently improving research in this field.

#### Acknowledgements

The Authors wish to acknowledge the University of Rome Tor Vergata and the Department of Civil and Computer Science Engineering of the same university for supporting this research within the funding program “Mission Sustainability”, project title “Structural safety monitoring system and structure-embedded event log system for new and existing buildings” (project code E86C18000340005).

#### References

- [1] Y.Lu, H.Ma, Z.Li, “Civil Infrastructures Connected Internet of Things”, *Current Adv. Civ. Eng.*, 2(1), 2014.
- [2] M.A.Mahmud, K.Bates, T.Wood, A.Abdelgawad and K.Yelamarthi, “A complete Internet of Things (IoT) platform for Structural, Health Monitoring (SHM),” 2018 IEEE 4th WF-IoT, Singapore, 2018.
- [3] S.Jeong, K.Law, “An IoT Platform for Civil Infrastructure Monitoring,” 2018 IEEE 42nd COMPSAC, Tokyo, 2018.
- [4] S.Hou, G.Wu, “A low-cost IoT-based wireless sensor system for bridge displacement monitoring”, *Smart Mat. Struct.*, 2019.
- [5] I.F.C.Smith, C.Alberto, “Cyber civil infrastructures”, chapter in *Future Cities Laboratory: Indicia 02*, Lars Müller Publishers, 2019.
- [6] M.Cosentino, “Il controllo strutturale permanente attraverso sensori nativi”, MS Thesis (in Italian), Univ. of Rome Tor Vergata, 2017.
- [7] D.Forconi, “Sistema di monitoraggio strutturale per l’edilizia storica in muratura tramite reti wireless a controllo remoto”, MS Thesis (in Italian), Univ. of Rome Tor Vergata, 2018.

- 8 Abruzzese, Micheletti, Tiero, Cosentino, Forconi, Grizzi, Scarano, Vuth, Abiuso / *Structural Integrity Procedia* 00 (2019) 000–000
- [8] G.M.Grizzi, “Valutazione dello stato tensionale in esercizio di strutture in calcestruzzo armato mediante tecniche avanzate di monitoraggio”, MS Thesis (in Italian), Univ. of Rome Tor Vergata, 2018.
- [9] G.Scarano, “Tecniche avanzate di monitoraggio permanente per strutture in cemento armato”, MS Thesis (in Italian), Univ. of Rome Tor Vergata, 2019.
- [10] Hung-Fu Chang, Tzu-Kang Lin, Real-time Structural Health Monitoring System Using Internet of Things and Cloud Computing, Eleventh U.S. National Conf. on Earthquake Engineering Integrating Science, Engineering & Policy, June 25-29, 2018, Los Angeles, California.
- [11] V. B. Chandanshive , A. M. Kazi ,”Application of Internet of Things in Civil Engineering construction projects - A State of the Art”, 4th Int. Conference on “Computing for Sustainable Global Development”, 1st - 3rd March, 2017 Bharati Vidyapeeth's Institute of Computer Applications and Management (BVICAM), New Delhi, India.
- [12] A. Myers, Md Anam Mahmud, A. Abdelgawad, K. Yelamarthi, Toward Integrating Structural Health Monitoring with Internet of Things (IoT)”, 2016 IEEE Int. Conf. on Electro Information Technology (EIT), Grand Forks, ND, USA.
- [13] B. Chanv , S. Bakhru, V. Mehta, “Structural Health Monitoring System Using IOT and Wireless Technologies”, 2017 Int. Conf. on Intelligent Communication and Computational Techniques (ICCT), Manipal University Jaipur, Dec 22-23, 2017.